

*SADDLES ARE SEAL WELDED TO TANK

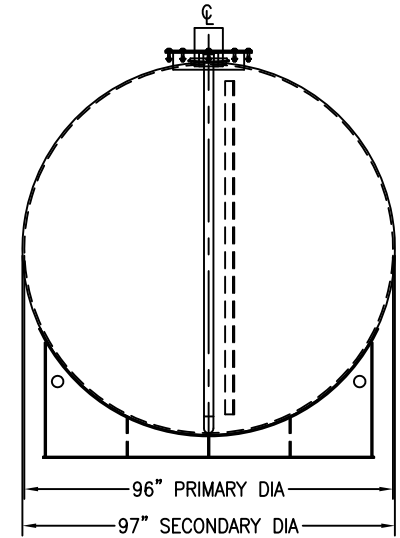

2" 90° LONG RADIUS ELBOW WITH 2" SCH. 40 PIPE AND 2" FNPT COUPLING (INTERSTITIAL MONITOR / LEAK DETECTION ACCESS)

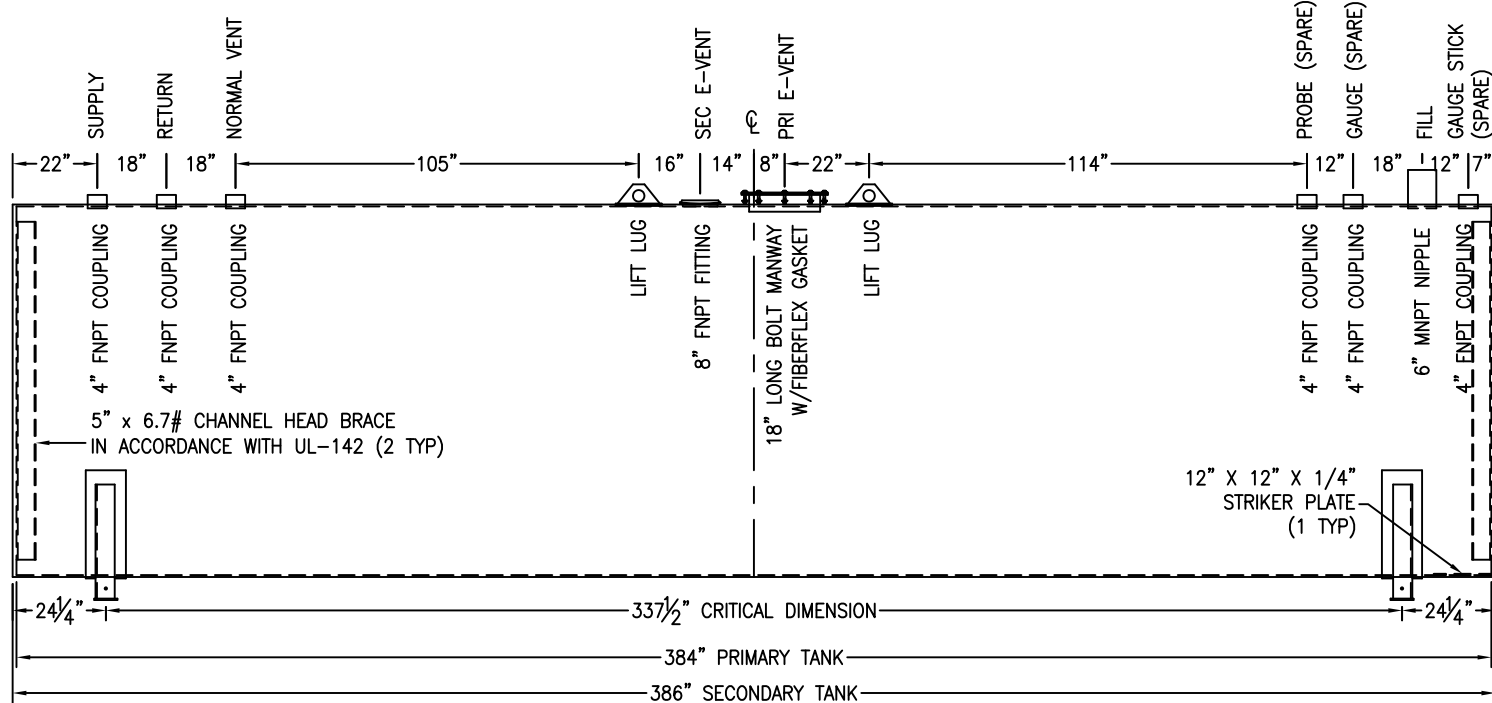

CUSTOMER APPROVAL SIGNATURE/DATE:

12,000 GALLON HORIZONTAL FLAMESHIELD D/W ABOVE GROUND TANK

SURFACE PREPARATION/COATING INFORMATION:
 INTERIOR SURFACES: N/A
 EXTERIOR SURFACES: SSPC-SP-6 COMMERCIAL BLAST CLEAN
 ONE COAT PRIMER

MATERIAL /CONSTRUCTION/ LABELING INFORMATION:
 MATERIAL: CARBON STEEL ASTM A 36 OR A 569
 MATERIAL THICKNESS: PRIMARY TANK SHELL AND HEADS: 1/4"
 SECONDARY TANK SHELL: 10 GA HEADS: 7 GA

LABELING/MARKING: UNDERWRITERS LABORATORIES UL-142 / STI FLAMESHIELD

CUSTOMER:
 PROJECT:
 AGENT:



P.O. BOX 1279 GOLDSBORO, NC 27533
 PHONE: (919)751-1791 FAX: (919)751-8186

DRAWING NUMBER: GIFS12K96 REVISED 9/08

QUANTITY: ONE (1) REQUIRED
 WEIGHT: 18,000 lbs ± 10%

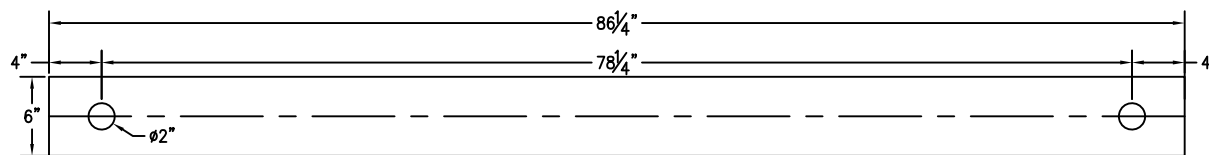

BASE PLATE ANCHOR HOLE DETAIL

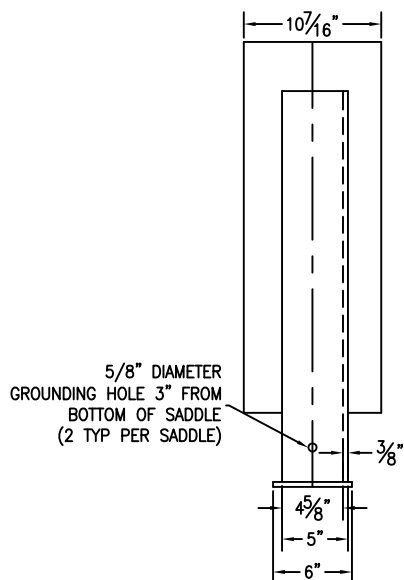

5/8" DIAMETER
 GROUNDING HOLE 3" FROM
 BOTTOM OF SADDLE
 (2 TYP PER SADDLE)

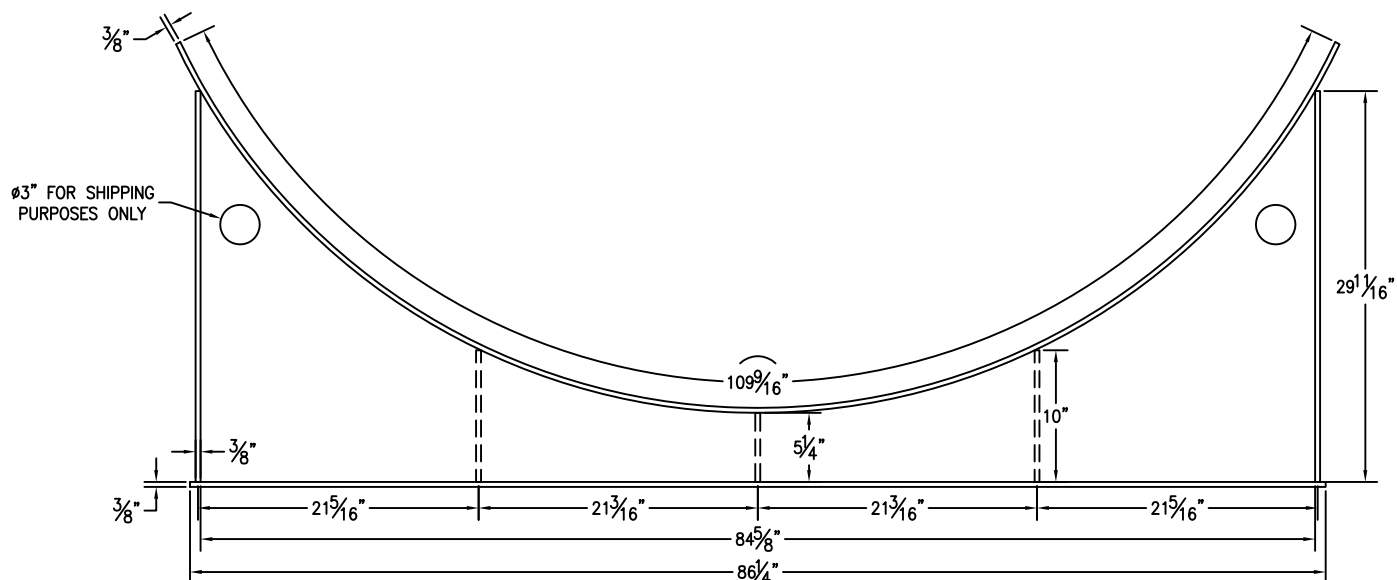

Ø3" FOR SHIPPING
 PURPOSES ONLY

CUSTOMER APPROVAL SIGNATURE/DATE:

12,000 GAL 6" TALL SADDLE FOR 97" DIAMETER TANK

SURFACE PREPARATION/COATING INFORMATION:
 INTERIOR SURFACES: N/A
 EXTERIOR SURFACES: SSPC-SP-6 COMMERCIAL BLAST CLEAN
 ONE COAT PRIMER

MATERIAL /CONSTRUCTION/ LABELING INFORMATION:
 MATERIAL: CARBON STEEL ASTM A 36 OR A 569

CUSTOMER:
 PROJECT:
 AGENT:



P.O. BOX 1279 GOLDSBORO, NC 27533
 PHONE: (919)751-1791 FAX: (919)751-8186

DRAWING NUMBER: GI-S609712DW REVISED 9/08

QUANTITY: TWO (2) REQUIRED
 WEIGHT: 377 lb ± 10%