

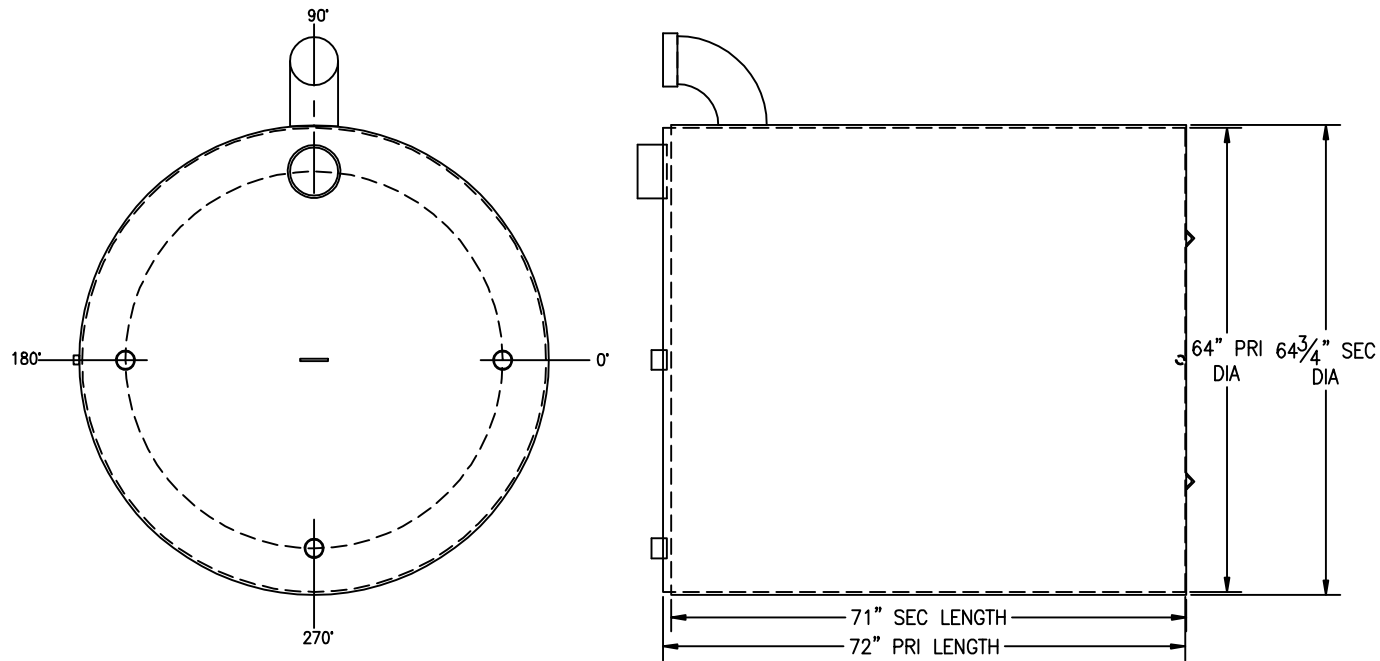

ANGLE:	LOCATION:	DESCRIPTION:
0°	TOP, 26" RADIUS	2" FNPT COUPLING
90°	SHELL	6" VERTICAL SECONDARY E-VENT
90°	TOP, 26" RADIUS	6" FNPT COUPLING
180°	TOP, 26" RADIUS	2" FNPT COUPLING
270°	SHELL	3/4" FNPT FITTING (INTERSTITIAL MONITOR)
270°	TOP, 26" RADIUS	2" FNPT COUPLING

STANDARD LAP/OFFSET WELD CONSTRUCTION TO UL-142 STANDARDS AND SPECIFICATIONS
 ALL BOLT HOLES TO STRADDLE MAJOR CENTERLINES OR THEIR PARALLELS



CUSTOMER APPROVAL SIGNATURE/DATE:

1000 GALLON VERTICAL D/W ABOVE GROUND TANK

CUSTOMER:

SURFACE PREPARATION/COATING INFORMATION:

MATERIAL /CONSTRUCTION/ LABELING INFORMATION:

PROJECT:

INTERIOR SURFACES:
 N/A

 EXTERIOR SURFACES:
 SSPC-SP-6 COMMERCIAL BLAST CLEAN
 ONE COAT PRIMER
 BLACK ASPHALTUM PAINT ON EXTERIOR BOTTOM

MATERIAL: CARBON STEEL (ASTM A 36, ASTM A 635 OR ASTM A 569)
 MATERIAL THICKNESS: PRIMARY TANK: 10 GA
 SECONDARY TANK: 10 GA

AGENT:

P.O. BOX 1279 GOLDSBORO, NC 27533
 PHONE: (919)751-1791 FAX: (919)751-8186
 DRAWING NUMBER:

QUANTITY: ONE (1) REQUIRED
 WEIGHT: 1,850 lbs ± 5%

CONSTRUCTION IN ACCORDANCE WITH UNDERWRITERS LABORATORIES UL-142 STANDARDS FOR STEEL ABOVEGROUND TANKS FOR FLAMMABLE AND COMBUSTIBLE LIQUIDS

LABELING/MARKING: UNDERWRITERS LABORATORIES UL-142 / GENERAL INDUSTRIES NAMEPLATE