

*SADDLES ARE SEAL WELDED TO TANK

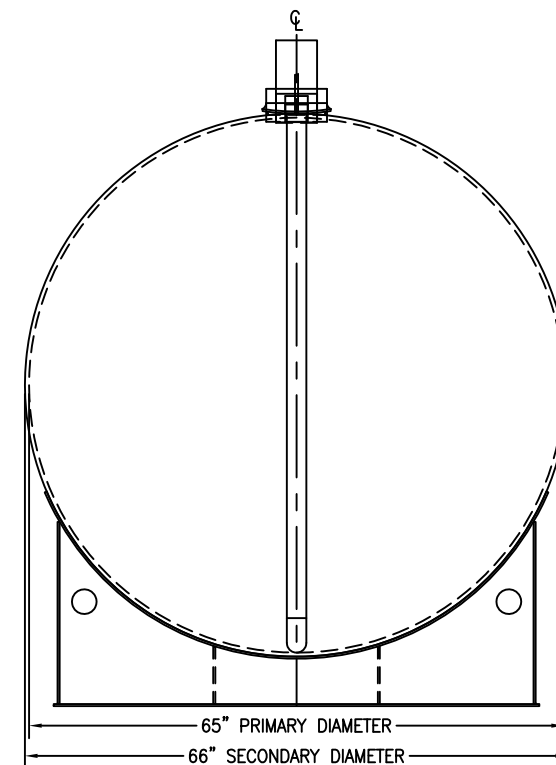
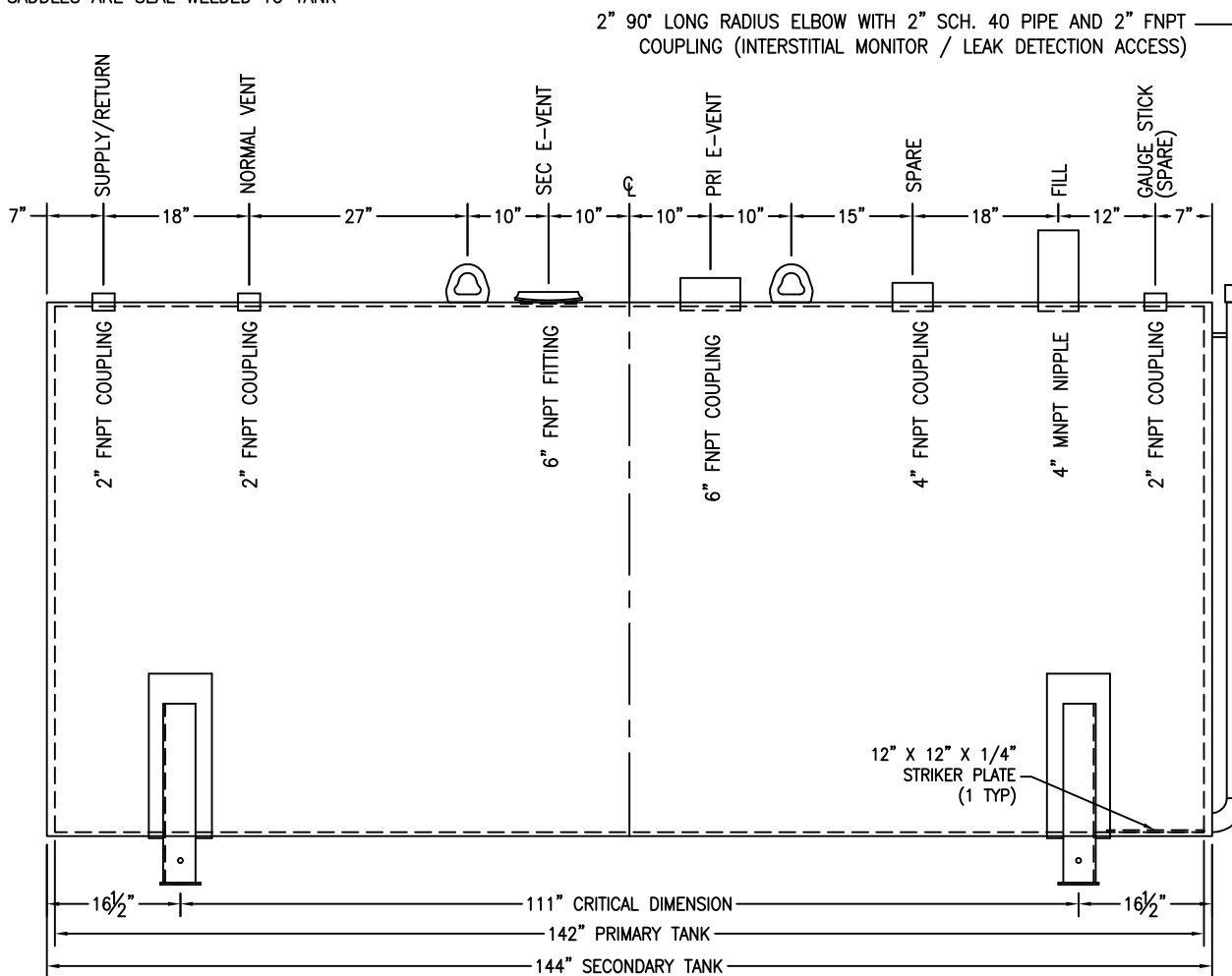

CUSTOMER APPROVAL SIGNATURE/DATE:

2,000 GALLON HORIZONTAL FLAMESHIELD D/W ABOVE GROUND TANK

SURFACE PREPARATION/COATING INFORMATION:
 INTERIOR SURFACES: N/A
 EXTERIOR SURFACES: SSPC-SP-6 COMMERCIAL BLAST CLEAN
 ONE COAT PRIMER

MATERIAL /CONSTRUCTION/ LABELING INFORMATION:
 MATERIAL: CARBON STEEL ASTM A 36 OR A 569
 MATERIAL THICKNESS: PRIMARY TANK SHELL AND HEADS: 7 GA
 SECONDARY TANK SHELL AND HEADS: 10 GA

LABELING/MARKING: UNDERWRITERS LABORATORIES UL-142 / STI FLAMESHIELD

CUSTOMER:

PROJECT:

AGENT:



P.O. BOX 1279 GOLDSBORO, NC 27533
 PHONE: (919)751-1791 FAX: (919)751-8186

DRAWING NUMBER: **GIFS02K65**

REVISED 9/08

QUANTITY: ONE (1) REQUIRED
 WEIGHT: 4,750 lbs ± 10%

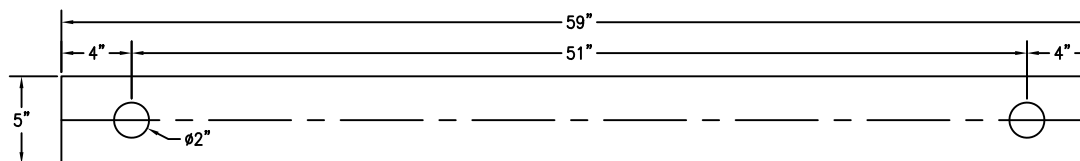

BASE PLATE ANCHOR HOLE DETAIL

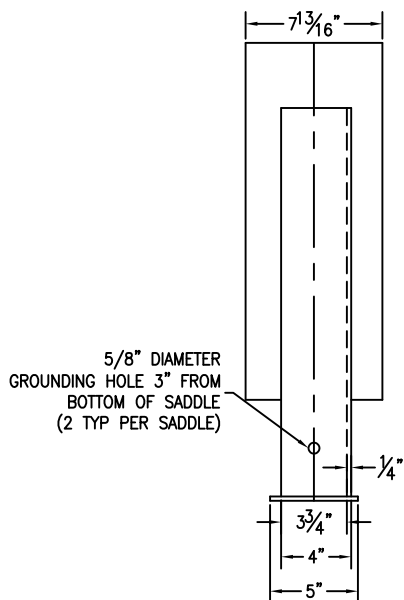

5/8" DIAMETER
 GROUNDING HOLE 3" FROM
 BOTTOM OF SADDLE
 (2 TYP PER SADDLE)

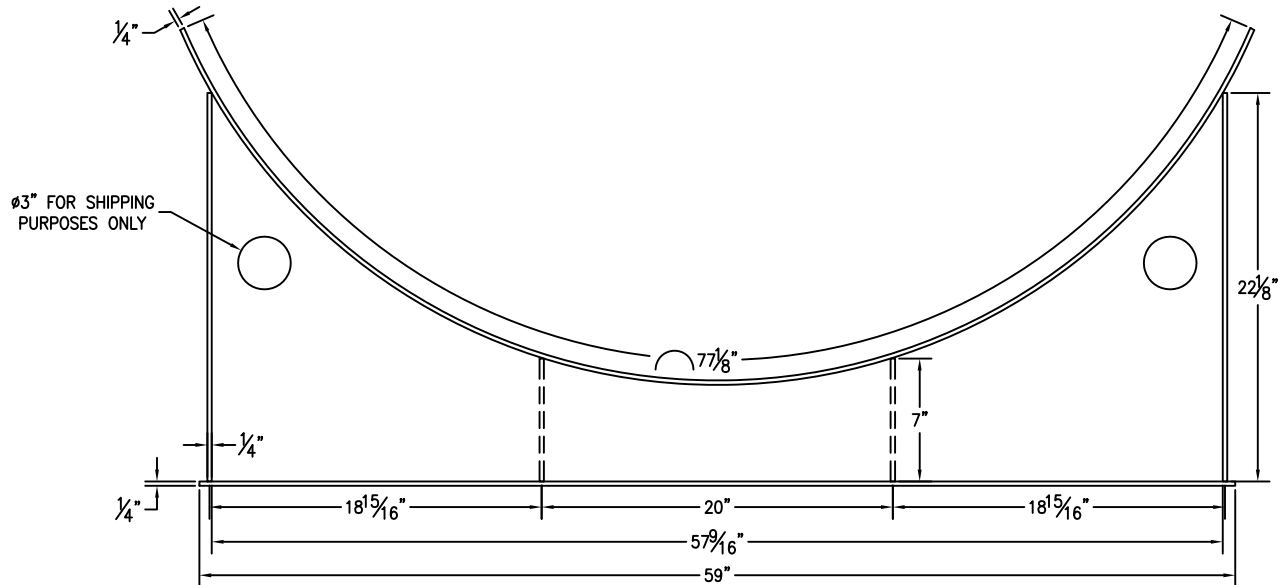

ø3" FOR SHIPPING
 PURPOSES ONLY

CUSTOMER APPROVAL SIGNATURE/DATE:

2,000 GAL 6" TALL SADDLE FOR 66" DIAMETER TANK

SURFACE PREPARATION/COATING INFORMATION:
 INTERIOR SURFACES: N/A
 EXTERIOR SURFACES: SSPC-SP-6 COMMERCIAL BLAST CLEAN
 ONE COAT PRIMER

MATERIAL /CONSTRUCTION/ LABELING INFORMATION:
 MATERIAL: CARBON STEEL ASTM A 36 OR A 569

CUSTOMER:
 PROJECT:
 AGENT:



P.O. BOX 1279 GOLDSBORO, NC 27533
 PHONE: (919)751-1791 FAX: (919)751-8186

DRAWING NUMBER: GI-S606602DW REVISED 9/08

QUANTITY: TWO (2) REQUIRED
 WEIGHT: 145 lb ea ± 10%