

\*SADDLES ARE SEAL WELDED TO TANK

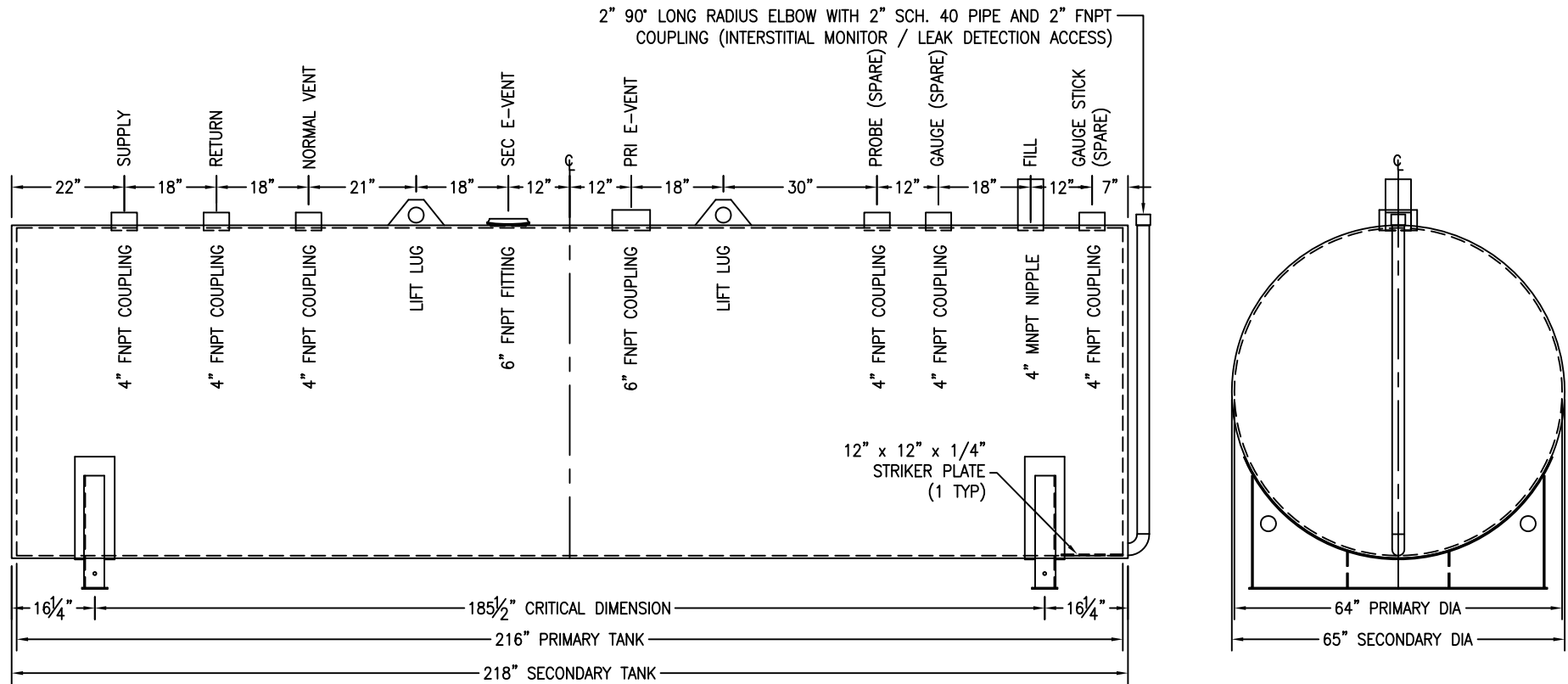

CUSTOMER APPROVAL SIGNATURE/DATE:

**3,000 GALLON HORIZONTAL FLAMESHIELD D/W ABOVE GROUND TANK**

**SURFACE PREPARATION/COATING INFORMATION:**  
 INTERIOR SURFACES: N/A  
 EXTERIOR SURFACES: SSPC-SP-6 COMMERCIAL BLAST CLEAN  
 ONE COAT PRIMER

**MATERIAL /CONSTRUCTION/ LABELING INFORMATION:**  
 MATERIAL: CARBON STEEL ASTM A 36 OR A 569  
 MATERIAL THICKNESS: PRIMARY TANK SHELL AND HEADS: 7 GA  
 SECONDARY TANK SHELL AND HEADS: 10 GA

**LABELING/MARKING:** UNDERWRITERS LABORATORIES UL-142 / STI FLAMESHIELD

CUSTOMER:  
 PROJECT:  
 AGENT:

**GENERAL INDUSTRIES**  
 BUILDING TANKS TO PROTECT  
 OUR ENVIRONMENT

P.O. BOX 1279 GOLDSBORO, NC 27533  
 PHONE: (919)751-1791 FAX: (919)751-8186

DRAWING NUMBER: **GIFS03K64** REVISED 9/08

QUANTITY: ONE (1) REQUIRED  
 WEIGHT: 6,000 lbs ± 10%

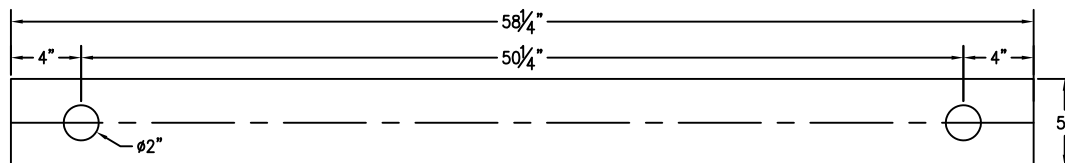

BASE PLATE ANCHOR HOLE DETAIL

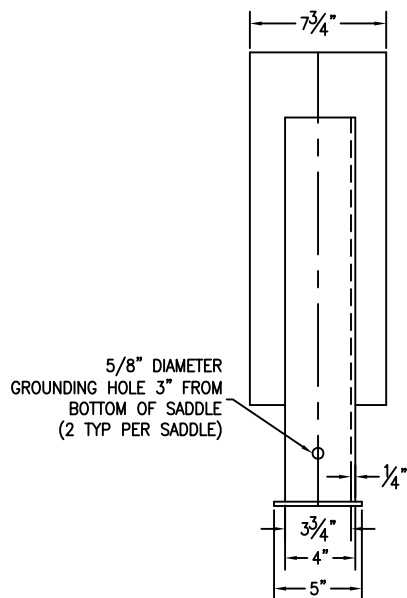

Ø3" FOR SHIPPING PURPOSES ONLY

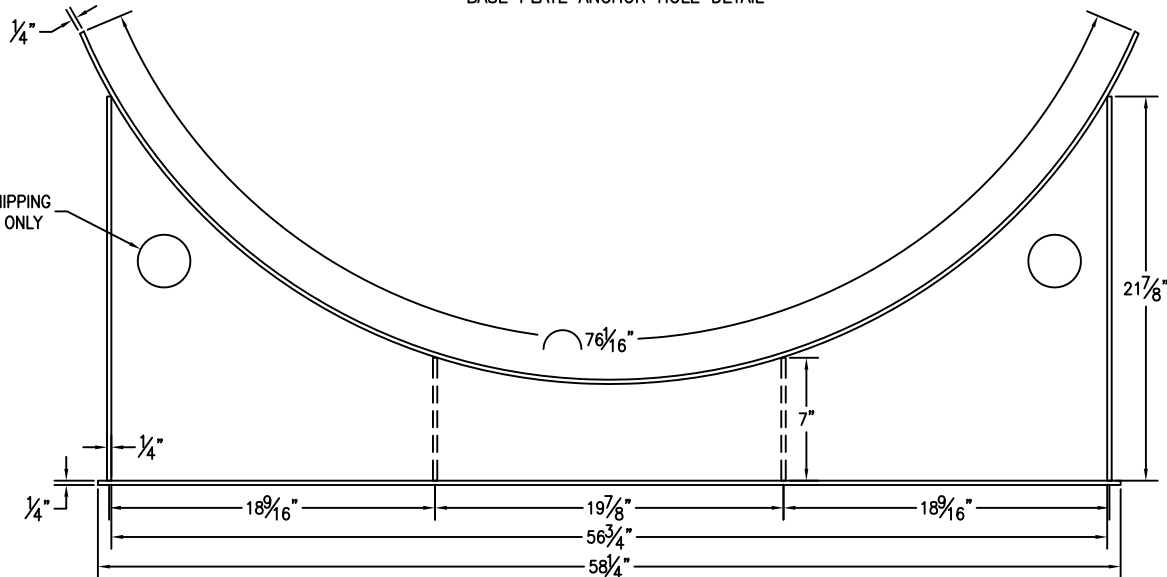

CUSTOMER APPROVAL SIGNATURE/DATE:

3,000 GAL 6" TALL SADDLE FOR 65" DIAMETER TANK

**SURFACE PREPARATION/COATING INFORMATION:**  
 INTERIOR SURFACES: N/A  
 EXTERIOR SURFACES: SSPC-SP-6 COMMERCIAL BLAST CLEAN  
 ONE COAT PRIMER

**MATERIAL /CONSTRUCTION/ LABELING INFORMATION:**  
 MATERIAL: CARBON STEEL ASTM A 36 OR A 569

CUSTOMER:  
 PROJECT:  
 AGENT:



P.O. BOX 1279 GOLDSBORO, NC 27533  
 PHONE: (919)751-1791 FAX: (919)751-8186

DRAWING NUMBER: **GI-S606503DW** REVISED 9/08

QUANTITY: TWO (2) REQUIRED  
 WEIGHT: 143 lb ea ± 10%