

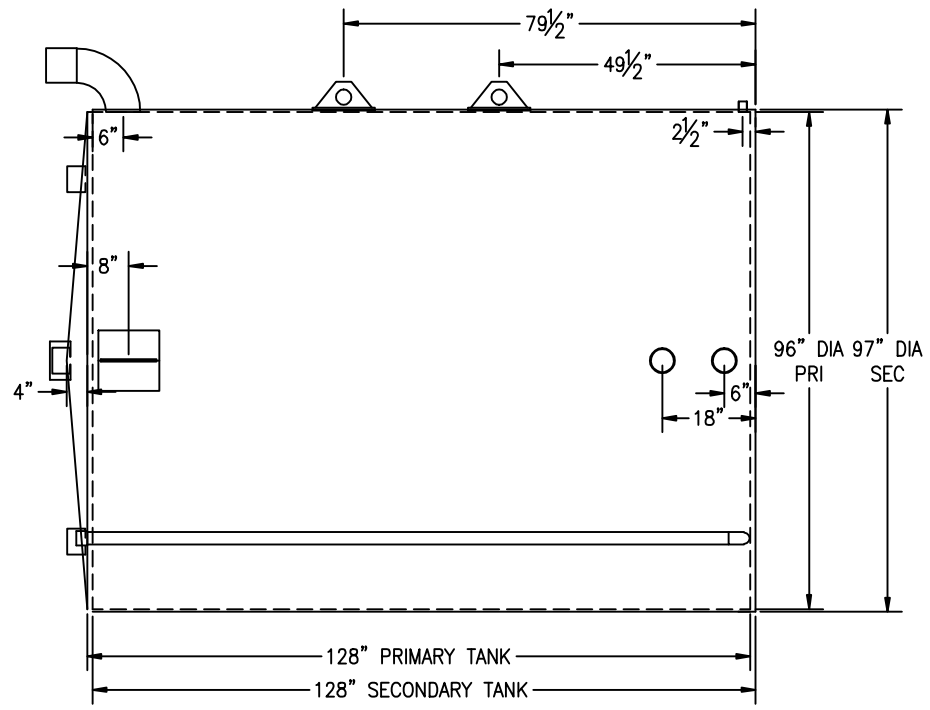

ANGLE:	LOCATION:	DESCRIPTION:	ANGLE:	LOCATION:	DESCRIPTION:
0°	SHELL, DOWN 8"	3/8" THICK ERECTION LUG w/ ROLLED REPAD	90°	SHELL, DOWN 6"	6" VERTICAL E-VENT
0°	SHELL, UP 6"	4" COUPLING	90°	TOP, 35" RADIUS	4" COUPLING
0°	SHELL, UP 18"	4" COUPLING	180°	SHELL, DOWN 8"	3/8" THICK ERECTION LUG w/ ROLLED REPAD
0°	TOP, 35" RADIUS	6" COUPLING	180°	TOP, 35" RADIUS	4" COUPLING
90°	SHELL, UP 2 1/2"	1" COUPLING	270°	TOP, 35" RADIUS	4" COUPLING
90°	SHELL, UP 49 1/2"	3/8" THICK LIFT LUG w/ ROLLED REPAD	315°	SHELL	2" FNPT COUPLING W/PIPE (INTERSTICE MONITOR)
90°	SHELL, UP 79 1/2"	3/8" THICK LIFT LUG w/ ROLLED REPAD			

STANDARD LAP/OFFSET WELD CONSTRUCTION TO UL-142 STANDARDS AND SPECIFICATIONS
 ALL BOLT HOLES TO STRADDLE MAJOR CENTERLINES OR THEIR PARALLELS

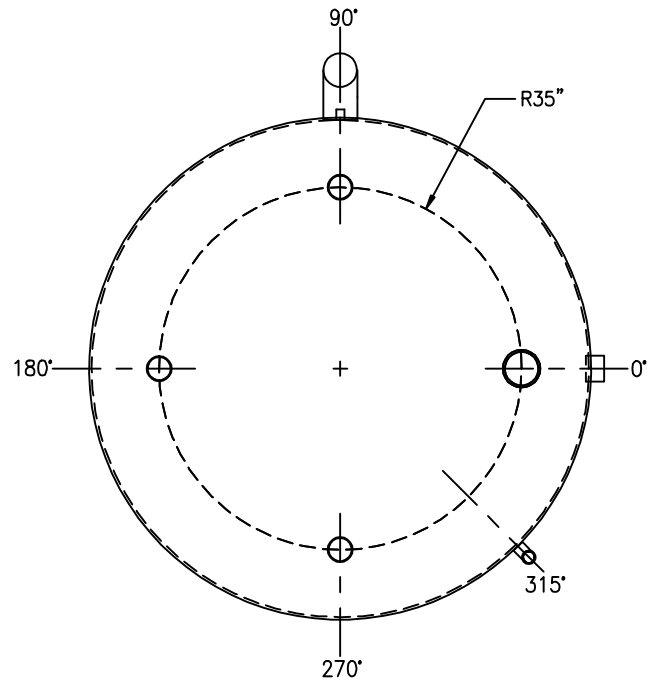

CUSTOMER APPROVAL SIGNATURE/DATE:

4,000 GALLON VERTICAL FLAMESHIELD D/W ABOVE GROUND TANK

SURFACE PREPARATION/COATING INFORMATION:

INTERIOR SURFACES:
 N/A
 EXTERIOR SURFACES:
 SSPC-SP-6 COMMERCIAL BLAST CLEAN
 ONE COAT PRIMER
 BLACK ASPHALTUM PAINT ON EXTERIOR BOTTOM

MATERIAL /CONSTRUCTION/ LABELING INFORMATION:

MATERIAL: CARBON STEEL (ASTM A 36, ASTM A 635 OR ASTM A 569)
 MATERIAL THICKNESS: PRIMARY TANK: TOP: 7 GA SHELL: 7 GA BOTTOM: 1/4"
 SECONDARY TANK: SHELL: 10 GA BOTTOM: 1/4"
 CONSTRUCTION IN ACCORDANCE WITH UNDERWRITERS LABORATORIES UL-142 / STI 921
 STANDARDS FOR STEEL ABOVEGROUND TANKS FOR FLAMMABLE AND COMBUSTIBLE LIQUIDS
 LABELING/MARKING: UNDERWRITERS LABORATORIES UL-142 /
 GENERAL INDUSTRIES NAMEPLATE

CUSTOMER:

PROJECT:

AGENT:



P.O. BOX 1279 GOLDSBORO, NC 27533
 PHONE: (919)751-1791 FAX: (919)751-8186

QUANTITY: ONE (1) REQUIRED
 WEIGHT: 5,300 lbs ± 5%

DRAWING NUMBER: