

*SADDLES ARE SEAL WELDED TO TANK

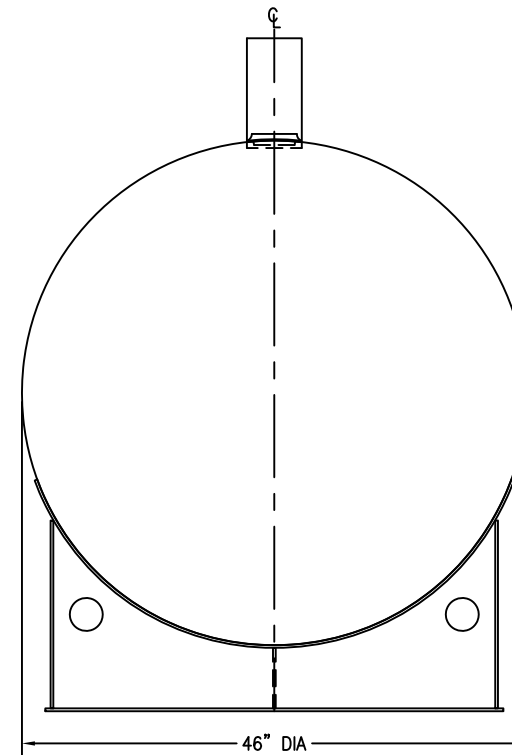
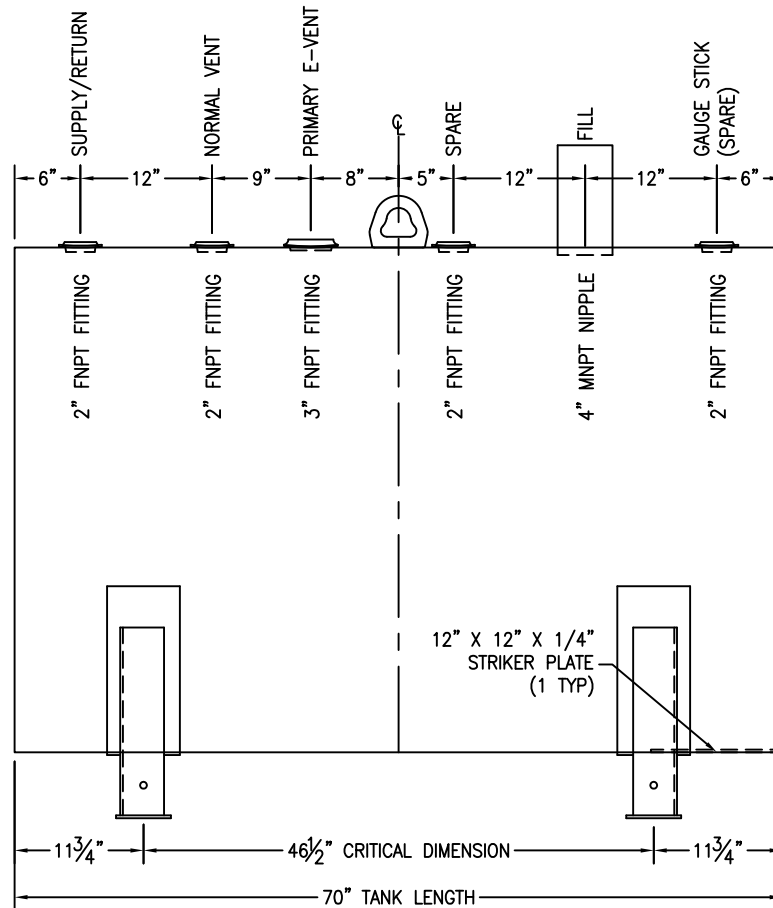

CUSTOMER APPROVAL SIGNATURE/DATE:

500 GALLON HORIZONTAL S/W ABOVE GROUND TANK

SURFACE PREPARATION/COATING INFORMATION:

INTERIOR SURFACES: N/A
 EXTERIOR SURFACES: SSPC-SP-6 COMMERCIAL BLAST CLEAN
 ONE COAT PRIMER

MATERIAL /CONSTRUCTION/ LABELING INFORMATION:

MATERIAL: CARBON STEEL ASTM A 36 OR ASTM A 569
 MATERIAL THICKNESS: PRIMARY TANK SHELL AND HEADS: 10 GA

LABELING/MARKING: UNDERWRITERS LABORATORIES UL-142

CUSTOMER:

PROJECT:

AGENT:



P.O. BOX 1279 GOLDSBORO, NC 27533
 PHONE: (919)751-1791 FAX: (919)751-8186

DRAWING NUMBER: GIH50046

REVISED 10/08

QUANTITY: ONE (1) REQUIRED
 WEIGHT: 1,500 lbs ± 10%

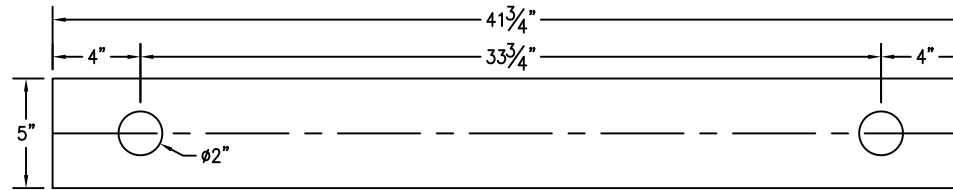

BASE PLATE ANCHOR HOLE DETAIL

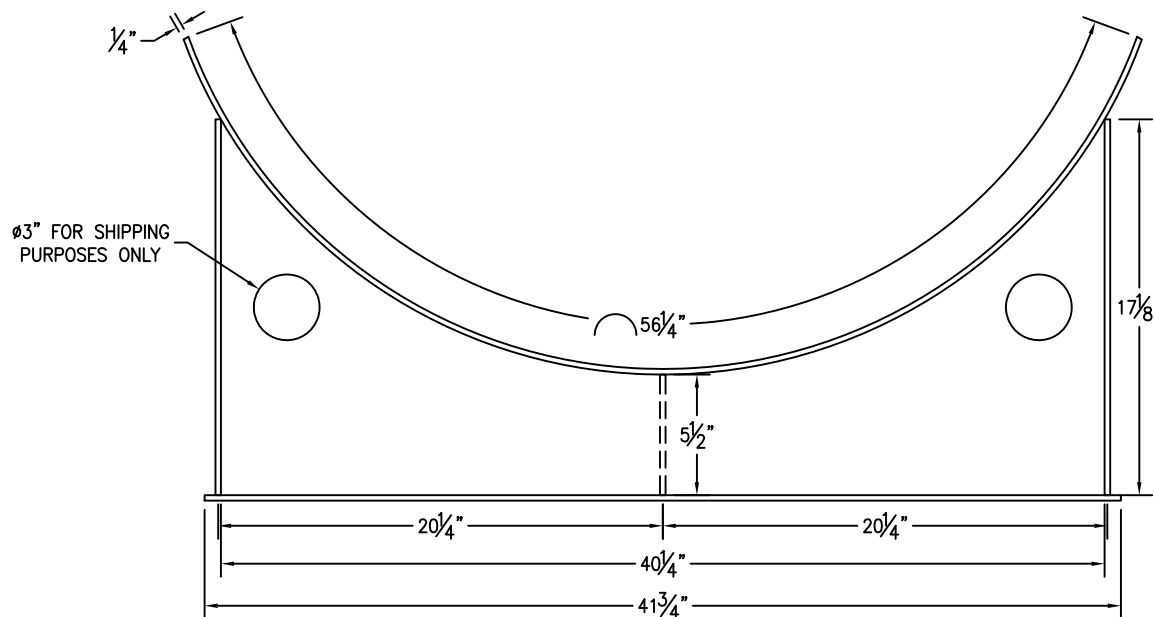
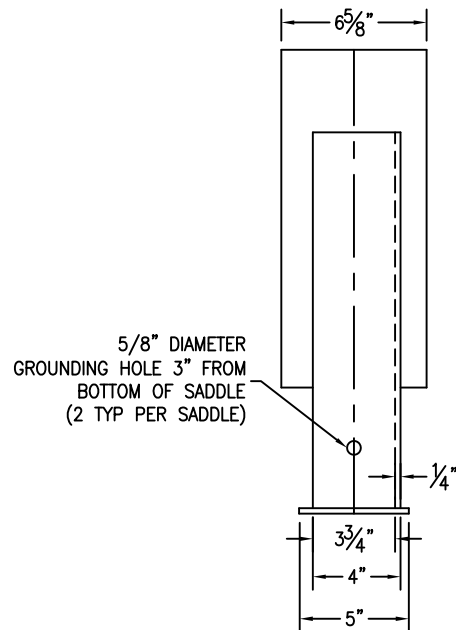

CUSTOMER APPROVAL SIGNATURE/DATE:

500 GAL 6" TALL SADDLE FOR 46" DIAMETER TANK

SURFACE PREPARATION/COATING INFORMATION:
 INTERIOR SURFACES: N/A
 EXTERIOR SURFACES: SSPC-SP-6 COMMERCIAL BLAST CLEAN
 ONE COAT PRIMER

MATERIAL /CONSTRUCTION/ LABELING INFORMATION:
 MATERIAL: CARBON STEEL ASTM A 36 OR ASTM A 569

CUSTOMER:
 PROJECT:
 AGENT:



P.O. BOX 1279 GOLDSBORO, NC 27533
 PHONE: (919)751-1791 FAX: (919)751-8186

DRAWING NUMBER: GI-S6046500 REVISED 10/08

QUANTITY: TWO (2) REQUIRED
 WEIGHT: 94 lbs ± 10%