

NOTES:

- 1) 1/4" THICK STRIKER PLATES INSTALLED ON THE TANK INTERIOR BOTTOM UNDER EACH OPENING IN ACCORDANCE WITH STEEL TANK INSTITUTE
- 2) ALL OPENINGS INSTALLED WITH DI-ELECTRIC BUSHINGS OR SPOOL FLANGES AND FLANGE ISOLATION KITS IN ACCORDANCE WITH STEEL TANK INSTITUTE
- 3) THIS TANK DESIGNED FOR MINIMUM BURIAL DEPTH OF 5 FEET (GRADE TO TOP OF TANK) WITH APPROVED BACKFILL MATERIAL *****

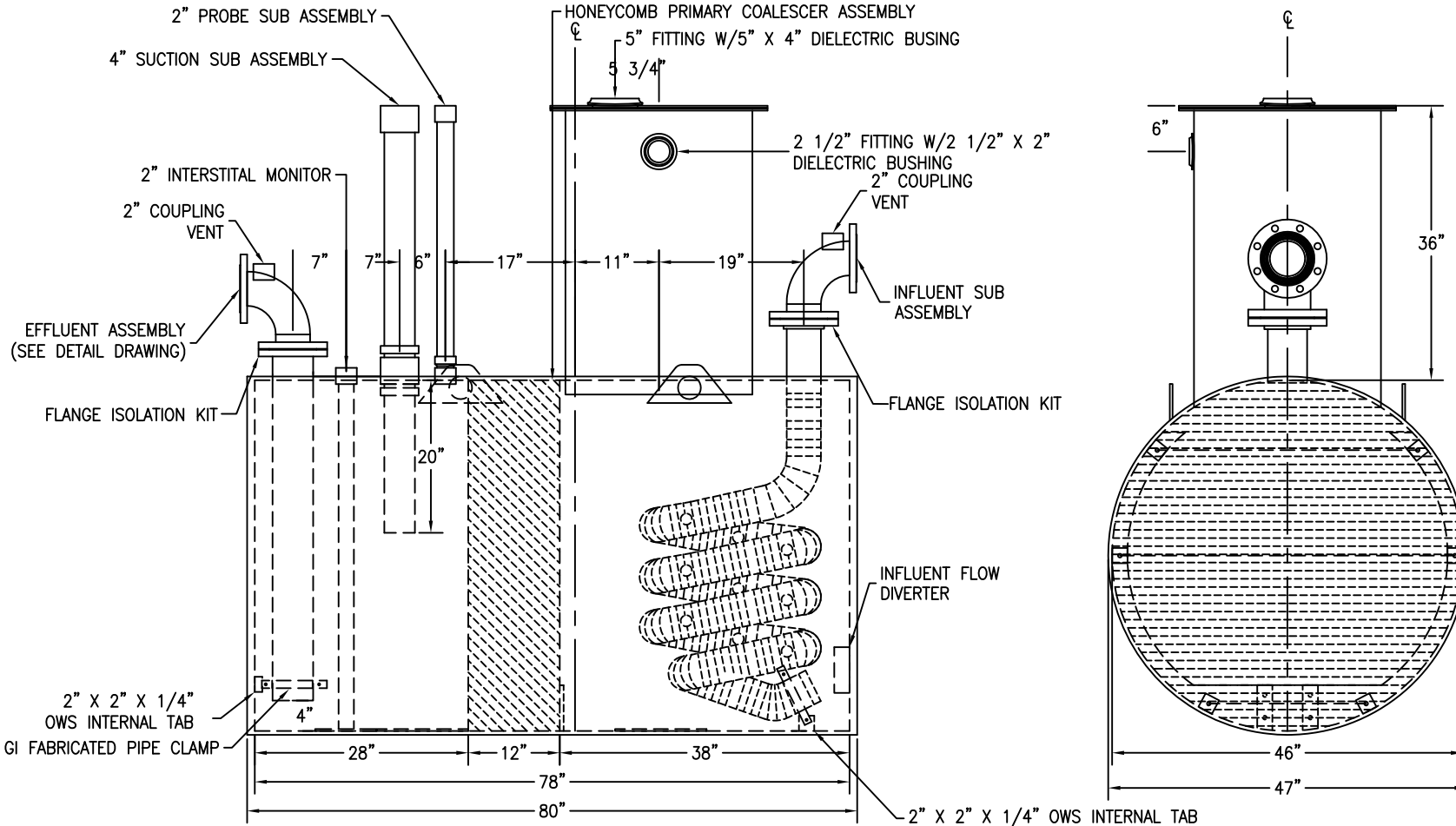

CUSTOMER APPROVAL SIGNATURE/DATE:

500 GALLON ACT 100U D/W 15PPM OIL WATER SEPARATOR

SURFACE PREPARATION/COATING INFORMATION:
 INTERIOR SURFACES: N/A
 EXTERIOR SURFACES: SSPC-SP-6 COMMERCIAL BLAST CLEAN
 70 mils STEEL INSTITUTE APPROVED POLYURETHANE COATING

MATERIAL /CONSTRUCTION/ LABELING INFORMATION:
 MATERIAL: CARBON STEEL ASTM A 36 OR ASTM A 569
 MATERIAL THICKNESS: PRIMARY TANK: ROARK MINIMUM .123 PRIMARY HEADS: 10 GA
 SECONDARY SHELL: 10 GA SECONDARY HEAD: 10 GA

QUANTITY: ONE (1) REQUIRED
 WEIGHT: 2,750 lbs ± 10%

LABELING/MARKING: UNDERWRITERS LABORATORIES UL-58/ STEEL TANK INSTITUTE
 ACT100-U

CUSTOMER:
 PROJECT:
 AGENT:



P.O. BOX 1279 GOLDSBORO, NC 27533
 PHONE: (919)751-1791 FAX: (919)751-8186
 DRAWING NUMBER: **GIDOWS500U15** REVISED 10/08

EFFLUENT ASSEMBLY

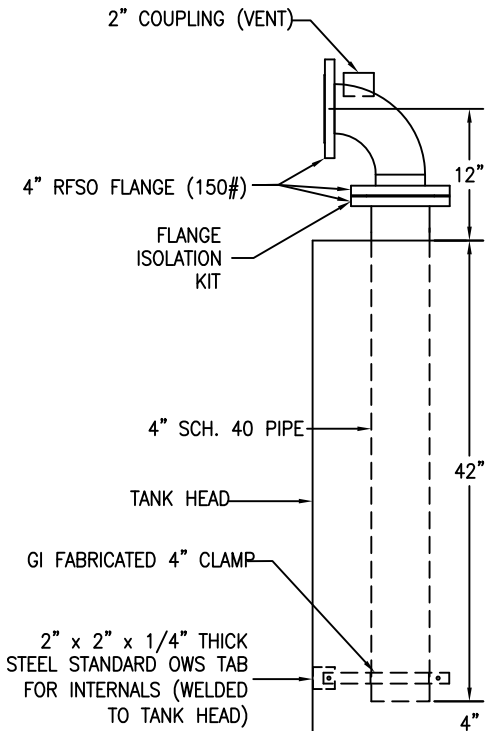

PROBE EXTENSION PIPE AND OIL SUCTION PIPE

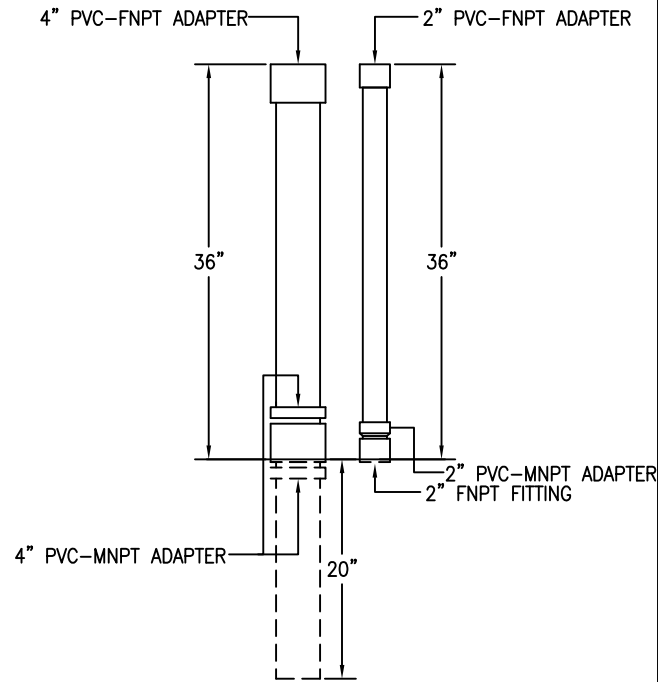

INFLUENT ASSEMBLY

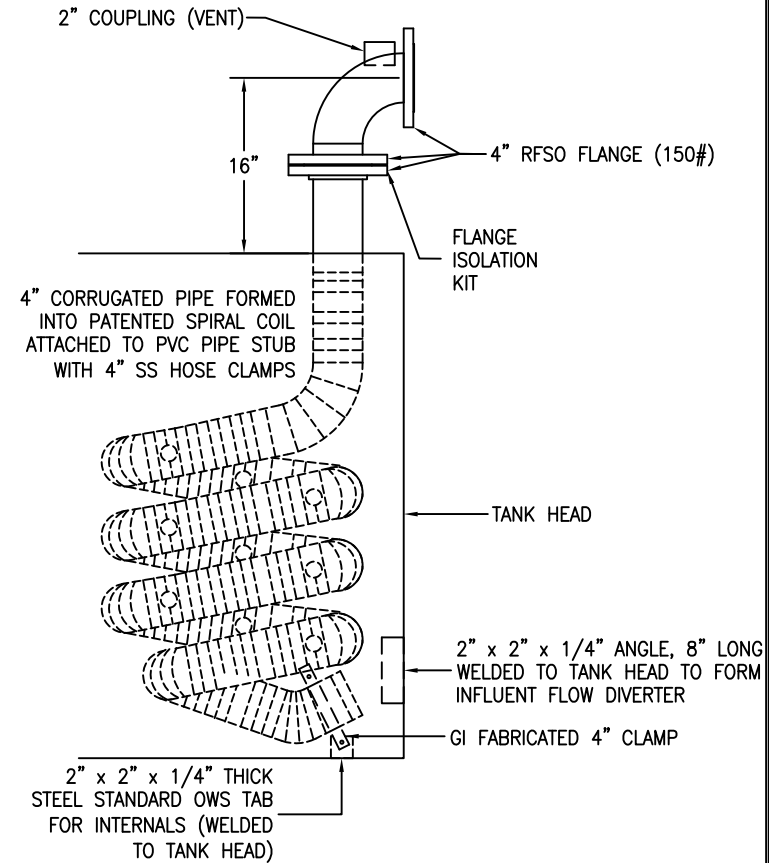

CUSTOMER APPROVAL SIGNATURE/DATE:

INFLUENT, EFFLUENT AND PROBE EXTENSION DETAILS

SURFACE PREPARATION/COATING INFORMATION:

MATERIAL /CONSTRUCTION/ LABELING INFORMATION:

CUSTOMER:
PROJECT:
AGENT:



P.O. BOX 1279 GOLDSBORO, NC 27533
PHONE: (919)751-1791 FAX: (919)751-8186
DRAWING NUMBER: **GIDOWS500U15** REVISED 10/08

EFFLUENT SIDE CLIPS WELDED TO TANK SHELL SO BACK OF BRENTWOOD INDUSTRIES ACCUPAC PVC PARALLEL PLATE PACK "BLOCKS" ARE AT THE CENTERLINE OF THE TANK.

STAINLESS STEEL WIRE BETWEEN EACH PAIR OF CLIPS WILL HOLD THE ACCUPACK BLOCKS IN PLACE ON THE EFFLUENT SIDE.

OWS INTERNALS STANDARD TAB/CLIP

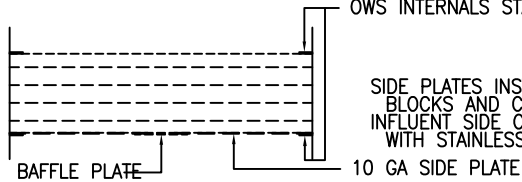

SIDE PLATES INSTALLED IN FRONT OF ACCUPACK BLOCKS AND CLIPS WELDED TO TANK SHELL. INFLUENT SIDE CLIPS SCREWED TO SIDE PLATES WITH STAINLESS STEEL SELF TAPPING SCREWS.

12" TALL x 8" WIDE 10 GA BAFFLE PLATE SCREWED TO SIDE PLATES WITH STAINLESS STEEL SELF TAPPING SCREWS.

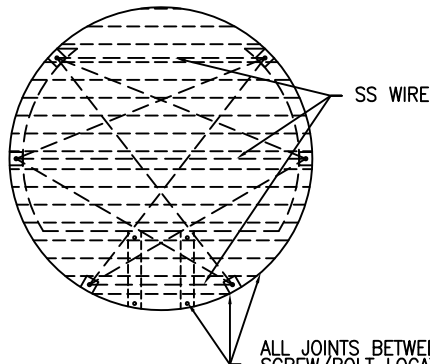

SS WIRE

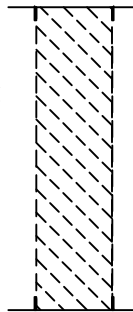

ALL JOINTS BETWEEN PLATES AND SHELL AND ALL SCREW/BOLT LOCATIONS TO HAVE HEAVY DUTY WATERPROOF CHEMICAL RESISTANT CAULKING LIBERALLY APPLIED

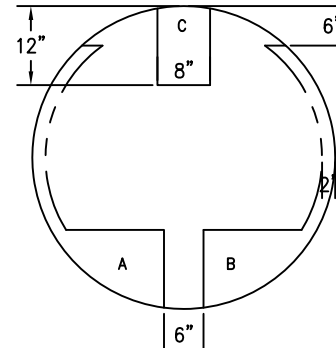

A - L. SIDE PLATE
B - R. SIDE PLATE
C - BAFFLE PLATE

CUT

46" ϕ x 10 GA BLANK

BAFFLE PLATE

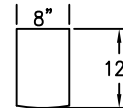

CUSTOMER APPROVAL SIGNATURE/DATE:

PARALLEL PLATE PACK COALESCER ASSEMBLY DETAILS

SURFACE PREPARATION/COATING INFORMATION:

MATERIAL /CONSTRUCTION/ LABELING INFORMATION:

CUSTOMER:

PROJECT:

AGENT:



P.O. BOX 1279 GOLDSBORO, NC 27533
PHONE: (919)751-1791 FAX: (919)751-8186

DRAWING NUMBER: GIDOWS500U15

REVISED 10/08