

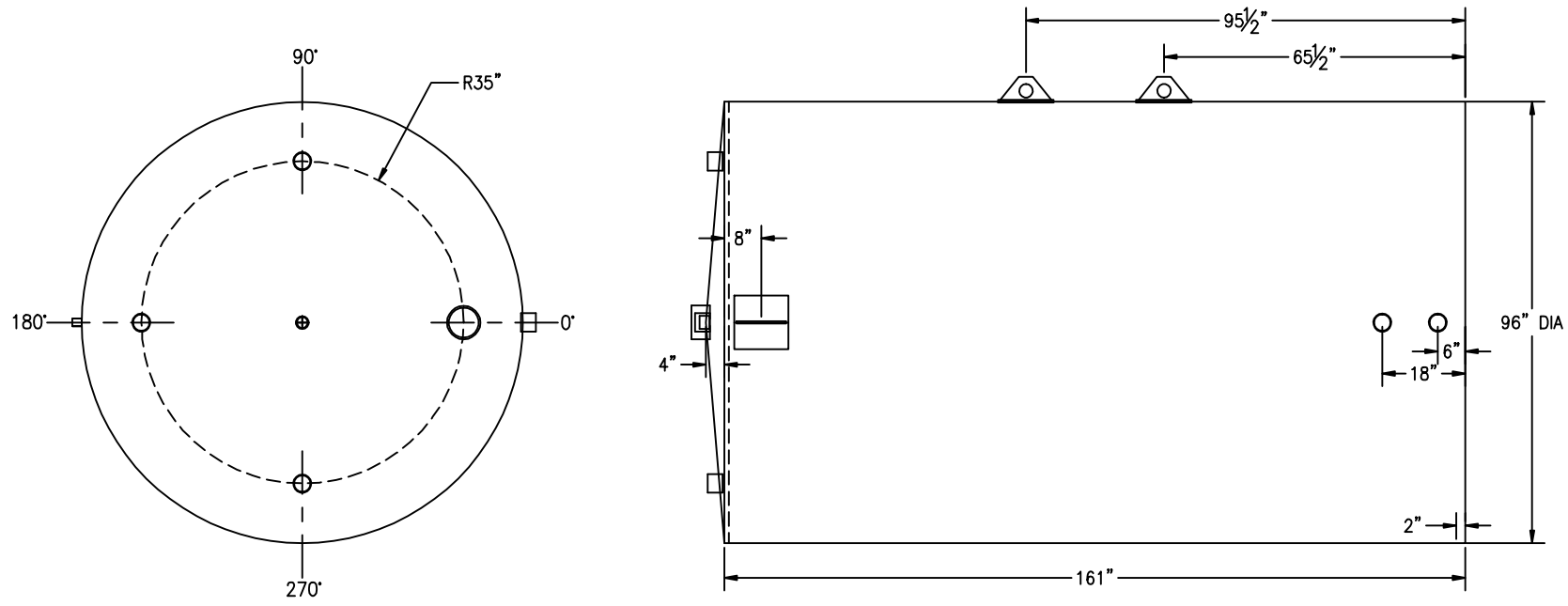

ANGLE:	LOCATION:	DESCRIPTION:	ANGLE:	LOCATION:	DESCRIPTION:
0°	SHELL, DOWN 8"	3/8" THICK ERECTION LUG w/ ROLLED REPAD	90°	TOP, 35" RADIUS	3" COUPLING
0°	SHELL, UP 6"	3" COUPLING	180°	SHELL, UP 2"	1" COUPLING
0°	SHELL, UP 18"	3" COUPLING	180°	SHELL, DOWN 8"	3/8" THICK ERECTION LUG w/ ROLLED REPAD
0°	TOP, 35" RADIUS	6" COUPLING (EMERGENCY VENT)	180°	TOP, 35" RADIUS	3" COUPLING
90°	SHELL, UP 65 1/2"	3/8" THICK LIFT LUG w/ ROLLED REPAD	270°	TOP, 35" RADIUS	3" COUPLING
90°	SHELL, UP 95 1/2"	3/8" THICK LIFT LUG w/ ROLLED REPAD	N/A	TOP, CENTER	2" COUPLING (NORMAL VENT)

STANDARD LAP/OFFSET WELD CONSTRUCTION TO UL-142 STANDARDS AND SPECIFICATIONS  
 ALL BOLT HOLES TO STRADDLE MAJOR CENTERLINES OR THEIR PARALLELS



CUSTOMER APPROVAL SIGNATURE/DATE:

**5,000 GALLON VERTICAL S/W ABOVE GROUND TANK**

**SURFACE PREPARATION/COATING INFORMATION:**

INTERIOR SURFACES:  
N/A

EXTERIOR SURFACES:  
SSPC-SP-6 COMMERCIAL BLAST CLEAN  
ONE COAT PRIMER  
BLACK ASPHALTUM PAINT ON EXTERIOR BOTTOM

**MATERIAL /CONSTRUCTION/ LABELING INFORMATION:**

MATERIAL: CARBON STEEL (ASTM A 36, ASTM A 635 OR ASTM A 569)  
 MATERIAL THICKNESS: PRIMARY TANK: TOP: 7 GA SHELL: 7 GA BOTTOM: 1/4"

CONSTRUCTION IN ACCORDANCE WITH UNDERWRITERS LABORATORIES UL-142 STANDARDS FOR STEEL ABOVEGROUND TANKS FOR FLAMMABLE AND COMBUSTIBLE LIQUIDS

LABELING/MARKING: UNDERWRITERS LABORATORIES UL-142 / GENERAL INDUSTRIES NAMEPLATE

CUSTOMER:  
PROJECT:  
AGENT:

P.O. BOX 1279 GOLDSBORO, NC 27533  
 PHONE: (919)751-1781 FAX: (919)751-8186  
 DRAWING NUMBER:

QUANTITY: ONE (1) REQUIRED  
 WEIGHT: 3,800 lbs ± 5%