

ANGLE:	LOCATION:	DESCRIPTION:
0°	SHELL, UP 6"	2" FNPT COUPLING
0°	SHELL, TBD	LIFTING LUG W/REPAD
0°	SHELL, TBD	LIFTING LUG W/REPAD
0°	TOP, 24" RADIUS	6" FNPT COUPLING (EMERGENCY VENT)
45°	BOTTOM	ANCHOR CHAIR
90°	TOP, 24" RADIUS	2" FNPT COUPLING
90°	SHELL, DOWN 8"	ERECTION LUG W/REPAD

ANGLE:	LOCATION:	DESCRIPTION:
135°	BOTTOM	ANCHOR CHAIR
180°	TOP, 24" RADIUS	2" FNPT COUPLING
225°	BOTTOM	ANCHOR CHAIR
270°	SHELL, DOWN 8"	ERECTION LUG W/REPAD
315°	BOTTOM	ANCHOR CHAIR
N/A	TOP, CENTER	2" FNPT COUPLING (NORMAL VENT)

**ALL WELDS DOUBLE BUTT
W/FULL PENETRATION**

ALL BOLT HOLES TO STRADDLE MAJOR CENTERLINES OR THEIR PARALLELS

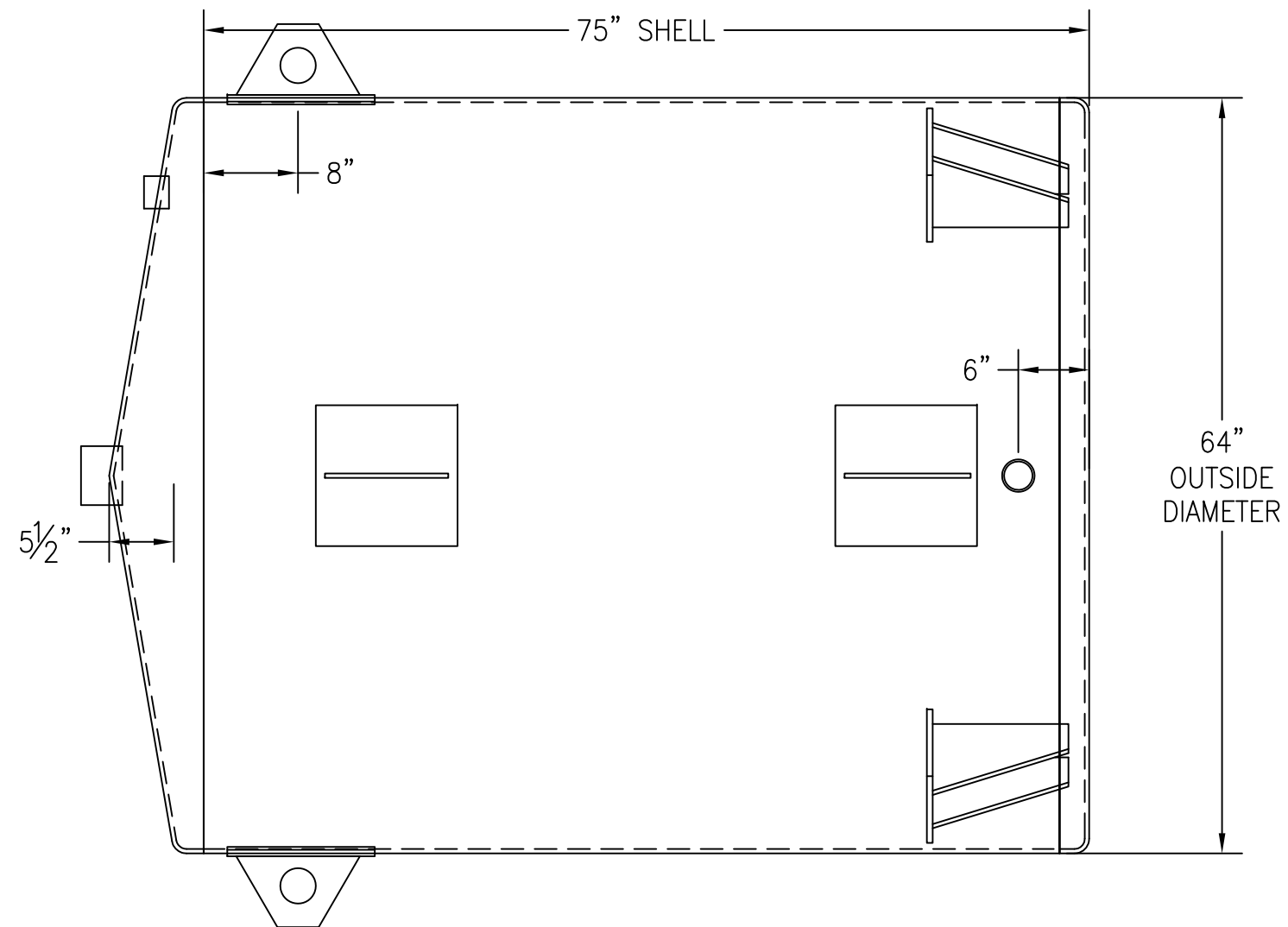
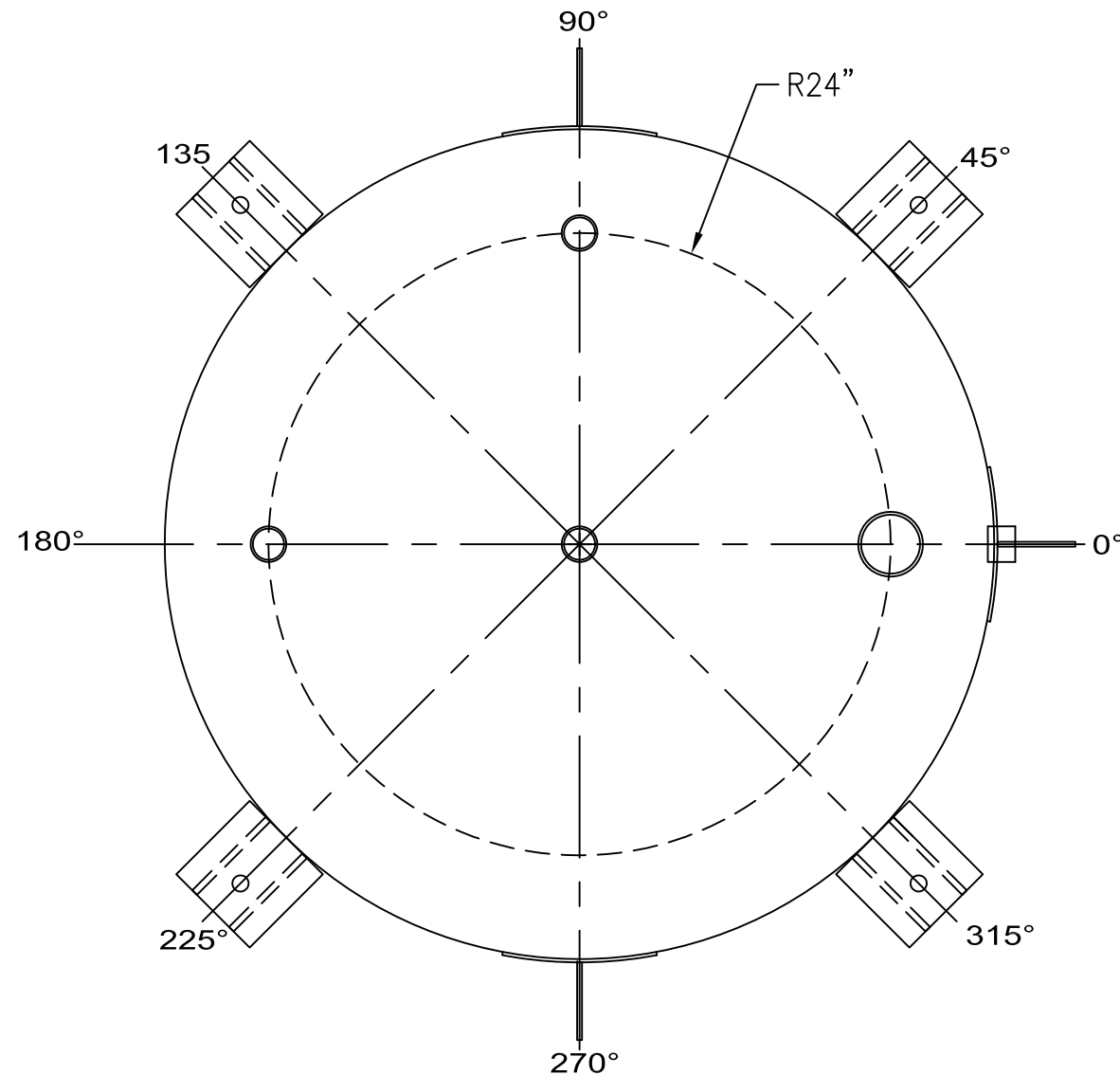

CUSTOMER APPROVAL SIGNATURE/DATE:

1000 GALLON VERTICAL S/W ABOVE GROUND SULFURIC ACID STORAGE TANK

SURFACE PREPARATION/COATING INFORMATION:

INTERIOR SURFACES: SSPC-SP-3 POWER TOOL CLEAN
WELDS ONLY REMOVE ALL LOOSE DEBRIS

EXTERIOR SURFACES:
SSPC-SP-6 COMMERCIAL BLAST CLEAN
ONE COAT WHITE URETHANE

MATERIAL /CONSTRUCTION/ LABELING INFORMATION:

MATERIAL: CARBON STEEL ASTM A 36 OR ASTM A 569
MATERIAL THICKNESS: 3/8"

LABELING/MARKING: API 650 APPENDIX J

CUSTOMER:

PROJECT:

AGENT:

GENERAL INDUSTRIES

P.O. BOX 1279 GOLDSBORO, NC 27533
PHONE: (919)751-1791 FAX: (919)751-8186

DRAWING NUMBER:
GICV-SA-0164

11/2014

QUANTITY: ONE (1) REQUIRED
WEIGHT: 3,500 lbs ± 10%