

\*SADDLES ARE SEAL WELDED TO TANK

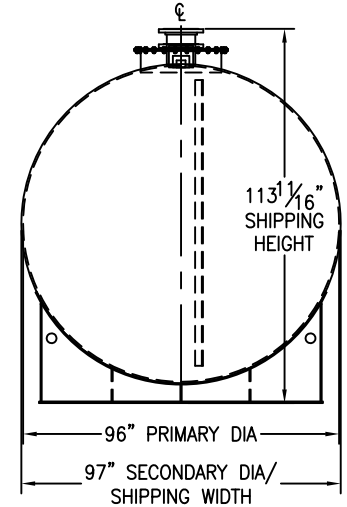

2" 90° LONG RADIUS ELBOW WITH 2" SCH. 40 PIPE AND 2" FNPT COUPLING (INTERSTITIAL MONITOR / LEAK DETECTION ACCESS)

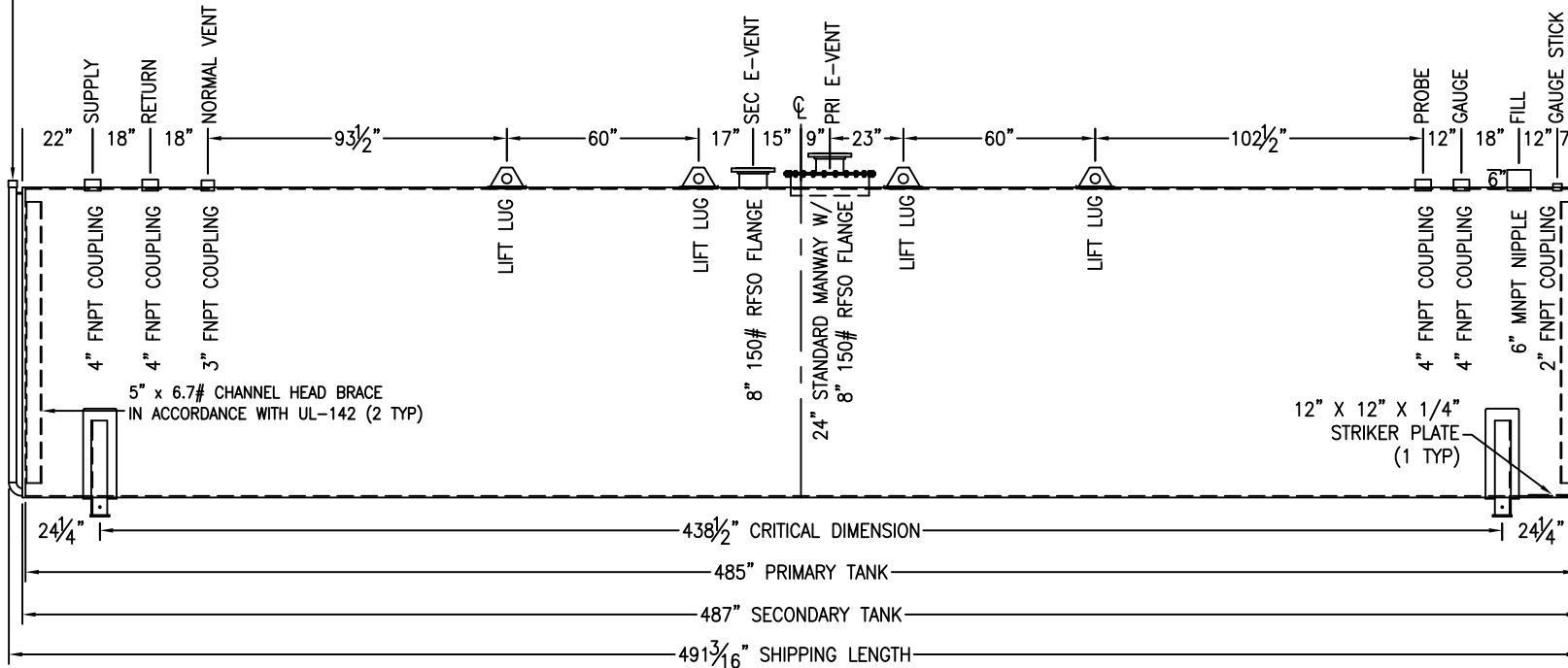

CUSTOMER APPROVAL SIGNATURE/DATE:

15,000 GALLON HORIZONTAL D/W ABOVE GROUND TANK

**SURFACE PREPARATION/COATING INFORMATION:**  
 INTERIOR SURFACES: SSPC-SP-3 POWER TOOL CLEAN WELDS ONLY  
 REMOVE ALL LOOSE DEBRIS  
 EXTERIOR SURFACES: SSPC-SP-6 COMMERCIAL BLAST CLEAN  
 5-7 MILS ALIPHATIC URETHANE (WHITE)

**MATERIAL /CONSTRUCTION/ LABELING INFORMATION:**  
 MATERIAL: CARBON STEEL ASTM A 36 OR A 569  
 MATERIAL THICKNESS: PRIMARY TANK SHELL AND HEADS: 1/4"  
 SECONDARY TANK SHELL: 10 GA HEADS: 1/4"

LABELING/MARKING: UNDERWRITERS LABORATORIES UL-142/STI F-921

CUSTOMER:  
 PROJECT:  
 AGENT:



P.O. BOX 1279 GOLDSBORO, NC 27533  
 PHONE: (919)751-1791 FAX: (919)751-8186  
 DRAWING NUMBER: GIDH15K96 REVISED 7/14

QUANTITY: ONE (1) REQUIRED  
 WEIGHT: 20,250 lbs ± 10%

\*SADDLES ARE SEAL WELDED TO TANK

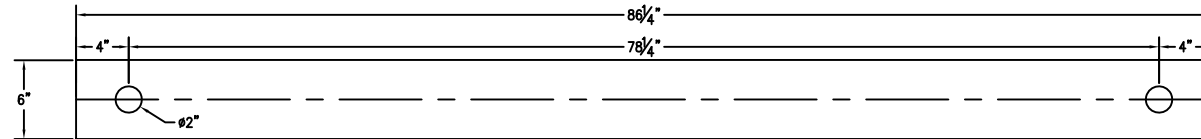

BASE PLATE ANCHOR HOLE DETAIL

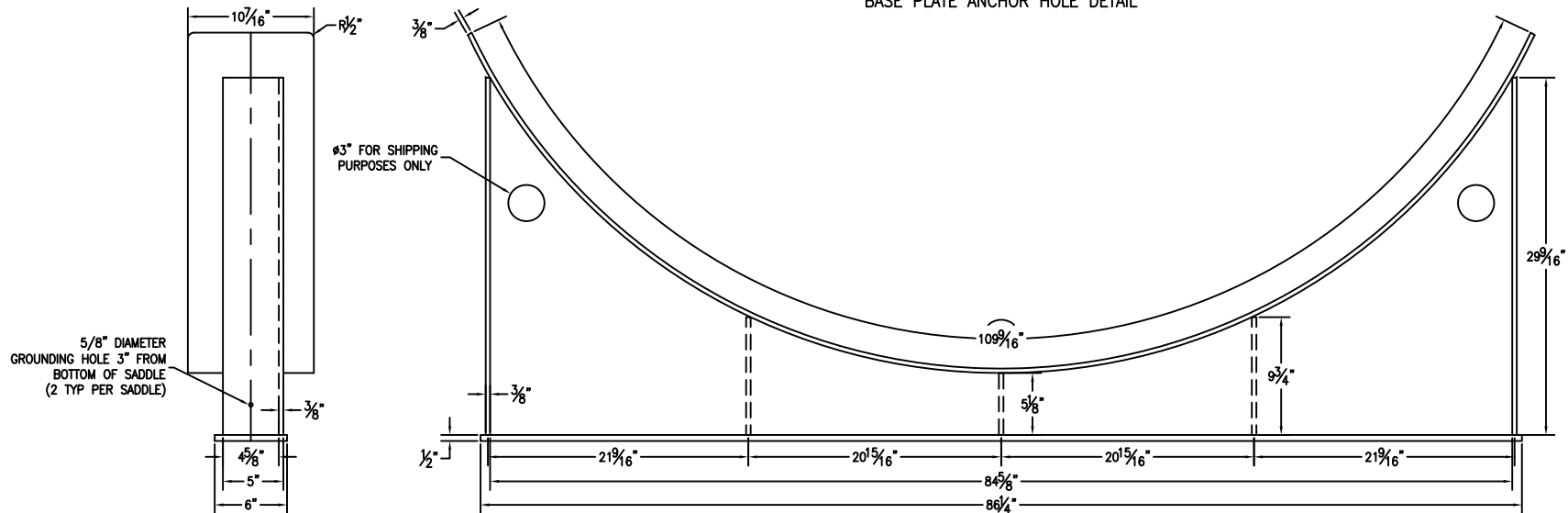

CUSTOMER APPROVAL SIGNATURE/DATE:

15,000 GAL 6" TALL SADDLE FOR 97" DIAMETER TANK

SURFACE PREPARATION/COATING INFORMATION:

MATERIAL /CONSTRUCTION/ LABELING INFORMATION:

EXTERIOR SURFACES: SSPC-SP-6 COMMERCIAL BLAST CLEAN  
5-7 MILS ALIPHATIC URETHANE (WHITE)

MATERIAL: CARBON STEEL ASTM A 36 OR A 569

CUSTOMER:  
PROJECT:  
AGENT:



P.O. BOX 1279 GOLDSBORO, NC 27533  
PHONE: (919)751-1791 FAX: (919)751-8186  
DRAWING NUMBER: GI-S609715DW  
REVISED 7/14

QUANTITY: TWO (2) REQUIRED  
WEIGHT: 395 lb ± 10%